

**Model No: SLCASH-CVR**

• SLD-12-1010-12T

• SLT12-20404-12T

**Material**

Detail	Specification	Quantity
Cover	Part H Cover	1
Screw	Plastic Screw M3x6mm	2
Screw	Self-Tapping Screw M3x6mm	2
Manual		1

**Assembly Instructions For Cover Installation**

- A. Adjust the "D" surface of the cover to overlap the exterior surface of the power supply chassis.
- B. Holding the cover at a slight angle to the power supply, line up the mounting holes.
- C. Line up "B" surface of the cover to the exterior "C" surface of the power supply (be careful not to pinch the wires).
- D. Fasten with provided mounting hardware as shown in the diagram below (Fig 1).

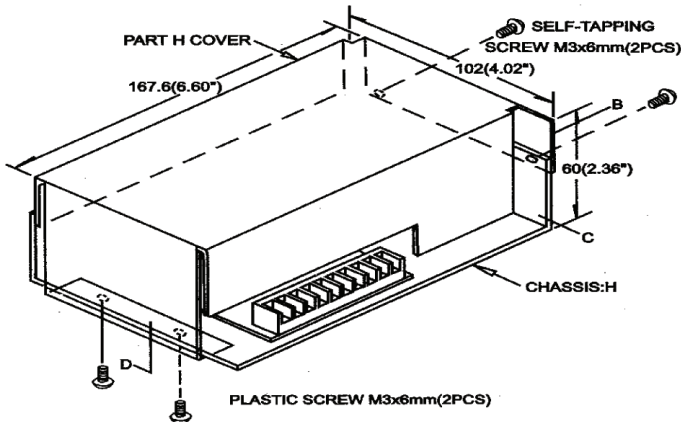

**Figure 1**

Contact Technical Services at 1-800-377-4384 or tech@sola-hevi-duty.com with any questions. Visit our website at www.solaheviduty.com

**Notes**

- A. Be very careful while assembling cover so that no partson the PCB are damaged.
- B. When tightening the screws, make sure the torque is 8kg.
- C. Derate power supply by 15% with cover installed.

**Assembly Instructions for OVP**

- A. Locate the mounting hole as shown in Fig 2.
- B. Attach SLO-12-000-TB tightly against the inner side of cover.
- C. Position the right mounting holes and tighten the screw with 8kg torque.
- D. Assemble the two wires coming out of the SLO-12-000-TB, the white one goes to the "+" out and the black one goes to the "-" out on terminal block.

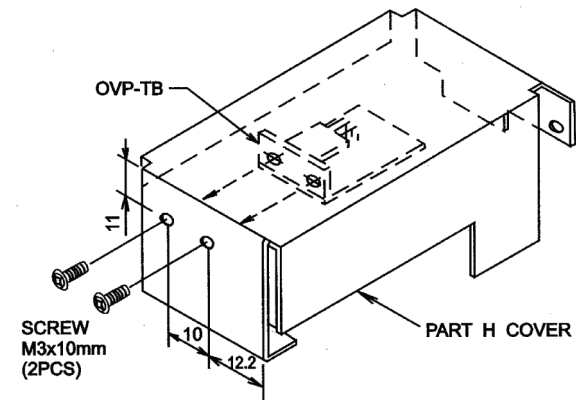

**Figure 2**

P/N: A272-114  
Rev. 1 (August 21, 2007)

Contact Technical Services at 1-800-377-4384 or tech@sola-hevi-duty.com with any questions. Visit our website at www.solaheviduty.com