

EGS

Electrical Group

**SOLA/
HEVI-DUTY**

**Series 4000
LRT™ Battery Cabinet**

for use with the
**2000-3000 VA
230V UPS Units**

USER MANUAL

English



IMPORTANT SAFETY INSTRUCTIONS

WARNING: Do not attempt to service this product yourself. Opening or removing the cover may expose you to dangerous voltages, even when the AC cord is disconnected from the electrical outlet. Refer all servicing to qualified service personnel.

1. **SAVE THESE INSTRUCTIONS.** THIS MANUAL CONTAINS IMPORTANT INSTRUCTIONS THAT SHOULD BE FOLLOWED DURING INSTALLATION AND MAINTENANCE OF THE BATTERY CABINET AND UNINTERRUPTIBLE POWER SYSTEM (UPS).
2. **This product is not intended for use with life support and other U.S. FDA designated "critical" devices. See Limited Warranty.**
3. **CAUTION:** A BATTERY PRESENTS A RISK OF ELECTRICAL SHOCK OR BURN FROM HIGH SHORT CIRCUIT CURRENT. OBSERVE PROPER PRECAUTIONS.
4. WHEN REPLACING THE BATTERIES, USE THE SAME NUMBER AND TYPE OF BATTERIES. PROPER DISPOSAL OF BATTERIES IS REQUIRED. REFER TO YOUR LOCAL CODES FOR DISPOSAL REQUIREMENTS.
5. Read all safety and operating instructions before operating the UPS and battery cabinet. Adhere to all warnings on the unit and in this manual. Follow all operating and user instructions.
6. Turn the UPS and battery cabinet off and unplug them before cleaning. Use only a soft cloth, never liquid or aerosol cleaners.
7. The UPS is designed for data processing equipment. Do not plug appliances, such as hair dryers, heaters, vacuum cleaners, or electric drills, into the UPS output receptacles. The Series 4000 LRT has a nominal voltage rating of 96VDC. The Series 4000 LRT is designed to operate only with the Sola Series 4000 1800/2000 and 2700/3000 VA rack tower (RT) UPS units with a sequential serial number 9915003001AF1T1 or greater. The LRT cabinets are capable of being paralleled in order to achieve longer run times (up to 8+ hours).
8. **WARNING:** Do not modify input cable. Consult your dealer if connector does not match the utility receptacle. The UPS and Battery Cabinet must be grounded at all times while in use. Turn the UPS and Battery Cabinet off before unplugging them, or the safety ground will be removed. Operate Battery Cabinet only from a properly grounded 120 or 230 VAC outlet (2 wire plus ground).
9. The Battery Cabinet is equipped with a grounded NEMA 5-15, or a grounded Schuko-type input power plug (depending upon input voltage). Do not defeat the safety purpose of this plug. If unable to fully insert the plug into the wall outlet, contact a qualified electrician for assistance.
10. Route power supply cords so they are not walked on or pinched.
11. Never block or insert any object into the ventilation holes or other openings. Maintain a clearance of four (4) inches in front and rear of the Battery Cabinet for proper airflow and cooling.
12. Servicing of batteries should be performed or supervised by personnel knowledgeable of batteries and the required precautions. Refer all servicing to qualified service personnel.
13. **CAUTION:** Do not open or mutilate the batteries. Released electrolyte is harmful to skin and eyes and may be toxic.
14. **CAUTION:** This equipment has been tested and complies with limits for a Class A digital device, pursuant to Subpart B of Part 15 of FCC rules; and the CE EMC directive. These limits provide reasonable protection against harmful interference when the equipment is operated in a commercial environment. This equipment generates, uses, and can radiate radio frequency energy. If it is not installed and used in accordance with the instruction manual, it may cause harmful interference to radio communications. Operation of this equipment in a residential area is likely to cause harmful interference that the user must correct at their own expense.
15. This equipment can be operated by individuals without previous training.

Unpacking the LRT

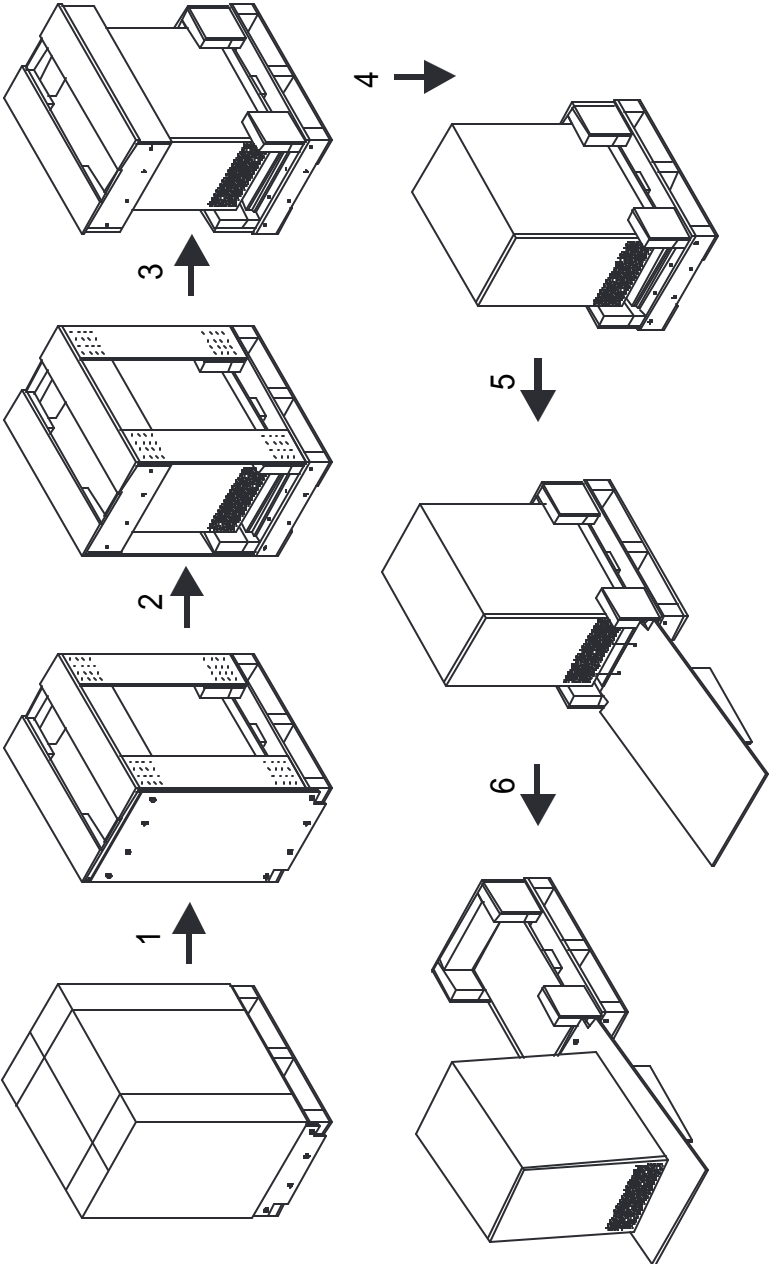

GENERAL INSTALLATION

LRT CABINET INSTALLATIONS

1. **CAUTION:** The LRT cabinet is heavy (see specifications). Take proper precautions when lifting or moving it.
2. Remove the retaining straps and protective cardboard covering from the shipping package.
3. Remove the 14mm (9/16") hex bolts from the side of the shipping crate. Retain one hex bolt and the side of the shipping crate.
4. Remove the four wood planks from each corner of the shipping crate. Remove the top of the shipping crate from the LRT cabinet.
5. Place the side of the shipping crate at the bottom of the crate and insert one hex bolt in the crate bottom. The LRT cabinet can now be rolled off of the shipping crate.
6. Visually inspect the LRT cabinet for freight damage. Report damage to the carrier and your dealer.
7. Locate the LRT cabinet indoors in a controlled environment, where it cannot be accidentally disconnected. Locate it in an area with unrestricted air flow, away from water, flammable liquids, gases, corrosives, or conductive contaminants. Maintain a minimum of 4 inches (100 mm) clearance in front and rear of the LRT cabinet. Battery cabinets are designed to be placed on either side of, or beneath the UPS. Maintain an ambient temperature range of 32° to 104° F (0° to 40° C).

NOTE: LRT cabinet operation in temperatures above 77° F (25° C) reduces battery life.

8. Plug the LRT cabinet into a dedicated wall receptacle properly protected by a circuit breaker or fuse in accordance with the National and Local Codes. Use a 15 amp rated device for 120VAC applications, or a 10 amp rated device for 230VAC applications. The wall receptacle must be grounded, and should be wired so as to experience outages simultaneously with the connected Series 4000 UPS.

CAUTION: Do not use the UPS output receptacles as the LRT input power source.

9. Connect the supplied cable to the battery cabinet then to the UPS. Turn on the charger by pressing the On switch located on the rear panel. Turn on the breaker on the rear of the battery cabinet. The LRT cabinet is ready for normal operation. Up to three optional LRT cabinets may be connected to the UPS to provide additional run time.

Series 4000 / LRT Installation

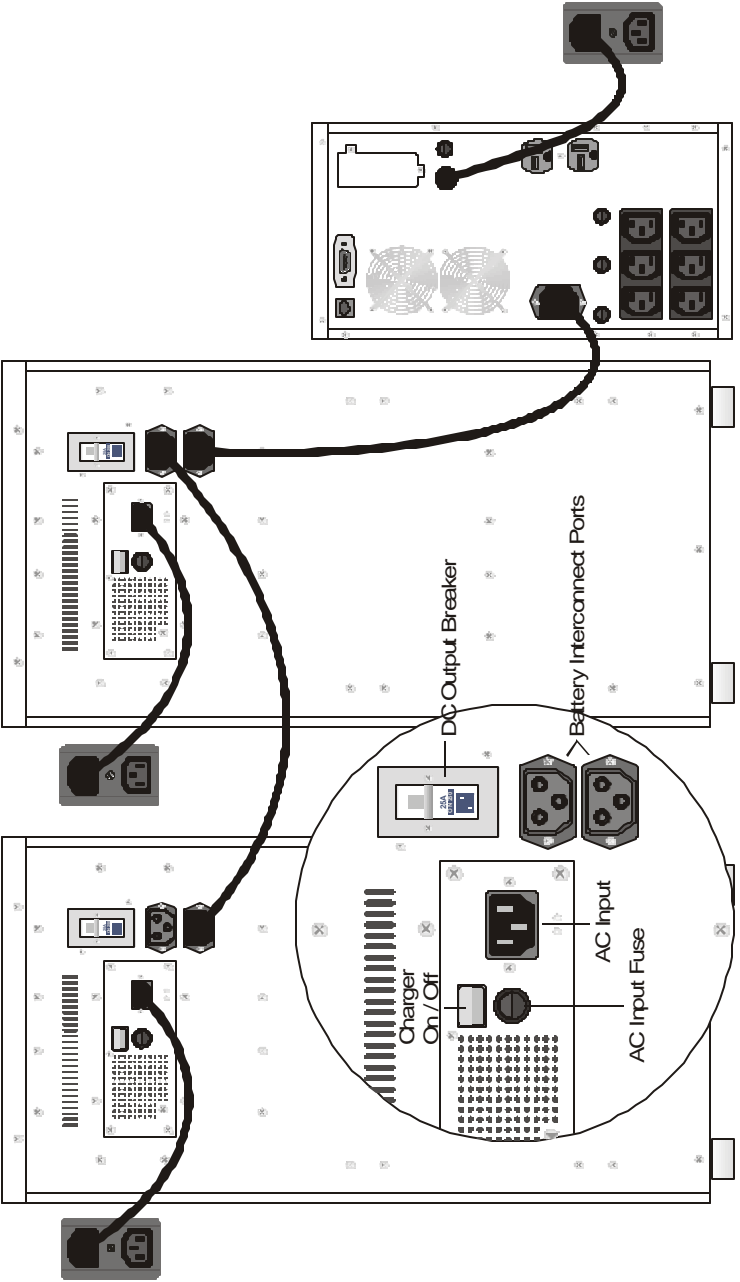

CONTROLS AND INDICATORS

On/Off Switch

This switch controls charger output. The switch is located on the rear of the unit and must be in the "Up" position to enable the charger.

Circuit Breaker Switch

This breaker is located on the rear of the unit and must be closed to allow the LRT Battery Cabinet to supply additional DC power to the UPS in the event of an interruption in commercial power. The switch must be in the "On" position to close the breaker.

Power Indicator (Green)

The Power indicator is located on the rear of the unit and is illuminated when the LRT Battery Cabinet is receiving commercial power and the internal charger is operating.

Summary Alarm (Red)

The Alarm indicator is located on the rear of the unit and is illuminated if the LRT Battery Cabinet has detected a problem. In addition, one or more of the UPS load/battery level indicators may be illuminated (refer to the UPS Troubleshooting Guide).

MAINTENANCE

The LRT Battery Cabinet requires very little maintenance. The batteries are valve regulated, nonspillable, lead acid, and should be kept charged to obtain their designed life. Periodically, examine the vents on the front and rear of the cabinet, and remove any obstructions from the surface of the vents.

When storing the LRT Battery Cabinet for any length of time, it is recommended to recharge the LRT Battery Cabinet for at least 24 hours every four to six months to increase battery life. In no case should the unit be stored in excess of nine months without recharge.

LRT™ Battery Cabinet Specifications

Model Number	2496 BAC
Compatible With Series 4000:	S42000 TRM-5 and S43000 TRM-5 UPS'.
DIMENSIONS: in. (mm)	
Unit W x D x H	381 x 686 x 737 (15 x 27 x 29)
WEIGHT: lbs (kg)	
Unit	272kg (600 lbs)
INPUT AC PARAMETERS	
Voltage Range	100 to 240 VAC
Frequency	50 / 60 Hz
Input Power Factor	>0.95
Current Reflected THD	30% THD maximum
Current Rating	< 4A at 120VAC, < 2A at 230VAC
Input Power Connection	IEC320-C14 recessed plug and (1) 1.8m cord with Schuko plug
Fuse Rating	6.3 A
OUTPUT DC PARAMETERS	
Output Sockets	(2) per LRT cabinet
Interconnect Cable	(1) 9.8' (3m) cable with appropriately keyed plugs
Protection	(1) resettable DC circuit breaker
BATTERY PARAMETERS	
Type	Valve-regulated, nonspillable, lead acid
Quantity x Voltage x Rating	8 x 12V x 65.0Ah
Approved Battery Manufacturers:	CSB, Panasonic, and Yuasa
Recharge Time	<20 Hours to 95% capacity after full discharge into 100% load
ENVIRONMENTAL	
Operating Temperature	+32° F to + 104° F (0° C to +40° C) for altitudes 0 to 5,000 ft (1,500m); +32° F to + 95° F (0° C to +35° C) for altitudes 5,000 ft (1,500m) to 10,000 ft (3,000m)
Storage Temperature	+5° F to + 122° F (-15° C to +50° C)
Relative Humidity	0% to 95%, non-condensing
Audible Noise	< 45 dBA, at 1 meter
AGENCY	
Safety	UL 1778; c-UL Listed; EN 50091-1; CE low voltage directive
Surge	IEEE 587 Category A; EN61000-4-5, Level 3 (L-E), Level 2 (L-L)
ESD	EN6100-4-2, Level 3
Susceptibility	EN6100-4-3, Level 2
Electrical Fast Transient/Burst	EN6100-4-4, Level 3
Immunity	EN50082-1
EMI/EMC	FCC Part15, Class A; EN50081-1; EN 55022, Class B; CE EMC Directive

LIMITED WARRANTY

Sola / Hevi-Duty extends the following LIMITED WARRANTY to the purchaser and to its customer (collectively referred to as the "Purchaser"): the enclosed Long Run Time Battery Cabinet (LRT) and components are free from defects in materials and workmanship under normal use, service, and maintenance FOR A PERIOD OF TWO YEARS FROM THE DATE OF ORIGINAL PURCHASE from Sola or the Sola dealer or retailer. THE FOREGOING WARRANTY IS THE ONLY WARRANTY GIVEN AND NO OTHER WARRANTY IS PROVIDED, EXPRESS OR IMPLIED, INCLUDING WITHOUT LIMITATION, MERCHANTABILITY OR FITNESS FOR A PARTICULAR PURPOSE. Certain aspects of disclaimers are not applicable to consumer products acquired by individuals and used for personal, family, or household purposes (as distinguished from industrial or other purposes). Local laws may not allow limitations on how long an implied warranty lasts, so the above limitation may not apply to you. This warranty gives you specific legal rights, and you may have other rights, which vary according to local law.

Certain repairs or services are the responsibility of the Purchaser and the Purchaser is expected to pay for them. This warranty does not extend either to products with removed or altered serial numbers or to any losses or damages due to act of God or source external to the product, misuse, accident, abuse, neglect, negligence, unauthorized modification, alteration, or repair, use beyond rated capacity, or improper installation, maintenance, application or use, including, without limitation, use in a manner contrary to the accompanying instructions or applicable codes. **WARNING:** Warranty is void if the battery is allowed to discharge below the minimum battery cutoff point. To prevent such discharge DO NOT leave the unit power switch "ON" for more than two (2) days without AC power being supplied to the LRT. The battery must be recharged every four (4) to six (6) months when not in use.

If the LRT fails to conform with the above warranty within the two year warranty period, Sola will repair or replace the LRT, at Sola's option. Repairs or replacements are warranted for the remainder of the original warranty period. Purchaser, to make a warranty claim, should call to obtain a Returned Goods Authorization number and shipping instructions. Return transportation costs to Sola are the responsibility of the Purchaser.

This product is not recommended, and the Company will not knowingly sell this product, for use with life support and other designated "critical" devices. ANY SUCH USE BY A USER AUTOMATICALLY VOIDS AND DISCLAIMS ANY AND ALL WARRANTIES, INCLUDING ANY IMPLIED WARRANTY OF MERCHANTABILITY, IMPLIED WARRANTY OF FITNESS FOR A PARTICULAR PURPOSE, AND EXPRESS WARRANTIES THAT THIS PRODUCT WILL CONFORM TO ANY AFFIRMATION OR PROMISE, FOR THIS PRODUCT AND THE USER AGREES THAT IN NO EVENT SHALL THE COMPANY BE LIABLE FOR CONSEQUENTIAL OR INDIRECT DAMAGES.



**SOLA/
HEVI-DUTY**

**Series 4000
LRT™ Battery Cabinet**

for use with the
2000-3000 VA
UPS Units

Technical Support

U.S. & Canada..... 1-800-377-4384

While every precaution has been taken to ensure accuracy and completeness in this manual, General Signal assumes no responsibility, and disclaims all liability for damages resulting from use of this information or for any errors or omissions.

©1999 Sola / Hevi-Duty All rights reserved throughout the world. Specifications subject to change without notice.

® Sola / Hevi-Duty name and logo are registered trademarks of General Signal, Inc. All names referred to are trademarks or registered trademarks of their respective owners.

SOI- 23455 (5/99) Rev. 1